



Yamaha YZF R1 (2004 - 2006)

Racing & Evolution Exhaust System

Akrapovic Racing & Evolution Exhaust System

for the Yamaha YZF R1 (2004 - 2006)

Supersport motorcycles like the Yamaha R1 call for top-quality aftermarket components, and the Akrapovic RACING / EVOLUTION systems definitely rank in that category. Installing one of these systems will make the engine come alive, with a huge 160.7 HP delivered to the rear wheel way up at 12730 rpm. Experienced riders and racers will be able to maximize the advantage offered by the Akrapovic RACING and EVOLUTION exhaust systems. In addition to the increased performance, the visual effect is also dramatic, as the systems fit right in to the sharp lines of the Yamaha.

PERFORMANCE

Measurements of the Akrapovic EVOLUTION system on the YAMAHA YZF R1(without muffler inserts):

Power & Torque: Akrapovic RACING/EVOLUTION systems allow the Yamaha engine to breathe to its fullest, as can be seen in both the power and torque curves. In addition to increased power, the system levels the power curve into a linear contour. The power increase begins at the low end at 3400 rpm and lasts up to 4600 rpm. From there to 6200 rpm the Akrapovic curve follows the stock curve. From 6200 rpm on the curve shows the qualities characteristic of the top Akrapovic systems. The increase runs all the way to the top of the rpm range, where it reaches max. power of 160.7 HP at 12730 rpm. The max. increased power is a massive 7.9 HP at 7200 rpm. The torque curve is even more eye-opening, as the system exerts an even greater influence on the stock curve. The drop-outs in the stock curve at around 3600 rpm and 7200 rpm are filled. The engine will be responsive at every point, allowing both racing intensity and smooth shifting at low revs.

CONFIGURATION

The Akrapovic RACING and EVOLUTION systems for the Yamaha R1 has a specific configuration of 4-2-1-2, which means: 4x header tubes run into a double collector, which is attached to a single Y-connecting tube, from which the dual mufflers are led under the seat. For the RACING system the header tubes are conical and made of stainless steel, the collectors are cylindrical and made of stainless steel, the Y-connecting tube is conical stainless steel, both link pipes are cylindrical titanium welded to the mufflers. The rest of the connections are sleeve joints held together with silicon-shielded tensioning springs. The mufflers are available with either titanium or carbon-fiber outer sleeves. Muffler outlet caps are made of carbon-fiber.

The tubes for the EVOLUTION system are all made entirely of titanium. The mufflers for the EVOLUTION are available in the same options as the RACING. All metal elements on the interior of the mufflers are entirely of titanium. The systems have a fitting on the Y-connecting tube for installing a lambda sensor. With Akrapovic RACING or EVOLUTION exhaust systems installed, the motorcycle's exhaust system will no longer contain a catalytic converter or EXUP valve.

	PERFORMANCE		
	stock	AKRAPOVIC	max. increased power
max. rear wheel power HP / rpm <small>(measured on SuperFlow Cycle Dyn)</small>	157.9 / 12770	160.7 / 12730	7.9 / 7200

	CONFIGURATION			
	header tubes	collector	Y-connecting tube	link pipe
material	TITANIUM (Evolution) STAINLESS STEEL (Racing)	TITANIUM (Evolution) STAINLESS STEEL (Racing)	TITANIUM (Evolution) STAINLESS STEEL (Racing)	TITANIUM (Evolution) TITANIUM (Racing)
tube shape	CONICAL	CYLINDRICAL	CONICAL	CYLINDRICAL

interference crossover tubes	NO	lambda sensor	YES
header tube inner sleeves	S.S. CNC MACHINED	header tube flanges	ALU CNC MACHINED
header tubes - collector connection	SLEEVE JOINT + SILICON SHIELDED SPRING	collector / header tube - link pipe connection	SLEEVE JOINT + SILICON SHIELDED SPRING
link pipe - muffler connection	WELDED	muffler inlet cap /outlet cap	TITANIUM / CARBON-FIBER
muffler metal interior	TITANIUM	muffler outer sleeve	TITANIUM / CARBON-FIBER
muffler clamp	CARBON-FIBER ROAD	muffler bracket	-
muffler insert	EU	NOISE DAMPER	-
	US	-	-
		catalytic converter	-

	ADDITIONAL DATA				
	stock	AKRAPOVIC		difference	
		RACING	EVOLUTION	stock - RACING	stock - EVOLUTION
weight comparison (kg)	8.91	7.20	6.10	1.71	2.81
noise measurements (dB / rpm)	stock		AKRAPOVIC		
	97 / 6250		97 / 6250 (Street Legal) 100.6 / 6250 (open)		
possibility of periodic service without removing A.E.S.	oil		oil filter		
	YES		YES		
legal for street use	YES (Street Legal version)				

Technical specifications of Akrapovic exhaust systems and related products subject to change without notice.

Product code: 106112 (S-Y10R6L-DTC/1), 106112 (S-Y10R6L-DTC/1) racing
 106088 (S-Y10RFT6TL-DTC/1), 106089 (S-Y10RFT6TL-DTT/1) evolution
 105611 (S-Y10EFT2TL-DTT/1) evolution KIT



Akrapovic Exhaust System Technology copyright 2006, all rights reserved

Road Program

Akrapovic Racing & Evolution Exhaust System for the Yamaha YZF R1 (2004 - 2006)



CARBON-FIBER
MUFFLER CLAMPS

Road
Program

Product code: 106112 (S-Y10R6L-DTC/1), 106112 (S-Y10R6L-DTC/1) racing
106088 (S-Y10RFT6TL-DTC/1), 106089 (S-Y10RFT6TL-DTT/1) evolution

Akrapovic Racing & Evolution Exhaust System for the Yamaha YZF R1 (2004 - 2006)



Akrapovic Exhaust System Technology copyright 2006, all rights reserved

Road
Program

Product code: 106112 (S-Y10R6L-DTC/1), 106112 (S-Y10R6L-DTC/1) racing
106088 (S-Y10RFT6TL-DTC/1), 106089 (S-Y10RFT6TL-DTT/1) evolution

Akrapovic Racing & Evolution Exhaust System for the Yamaha YZF R1 (2004 - 2006)



Akrapovic Exhaust System Technology copyright 2006, all rights reserved

Road Program

Product code: 106112 (S-Y10R6L-DTC/1), 106112 (S-Y10R6L-DTC/1) racing
106088 (S-Y10RFT6TL-DTC/1), 106089 (S-Y10RFT6TL-DTT/1) evolution

Akrapovic Racing & Evolution Exhaust System for the Yamaha YZF R1 (2004 - 2006)



CARBON-FIBER
MUFFLER CLAMPS

Product code: 105611 (S-Y10EFT2TL-DTT/1) evolution KIT

Akrapovic Racing & Evolution Exhaust System for the Yamaha YZF R1 (2004 - 2006)



Akrapovic Exhaust System Technology copyright 2006, all rights reserved

Road
Program

Product code: 105611 (S-Y10EFT2TL-DTT/1) evolution KIT

Akrapovic Racing & Evolution Exhaust System for the Yamaha YZF R1 (2004 - 2006)



Akrapovic Exhaust System Technology copyright 2006, all rights reserved

Road Program

Product code: 105611 (S-Y10EFT2TL-DTT/1) evolution KIT



Akrapovic Racing & Evolution Exhaust System

for the Yamaha YZF R1 (2004 - 2006)

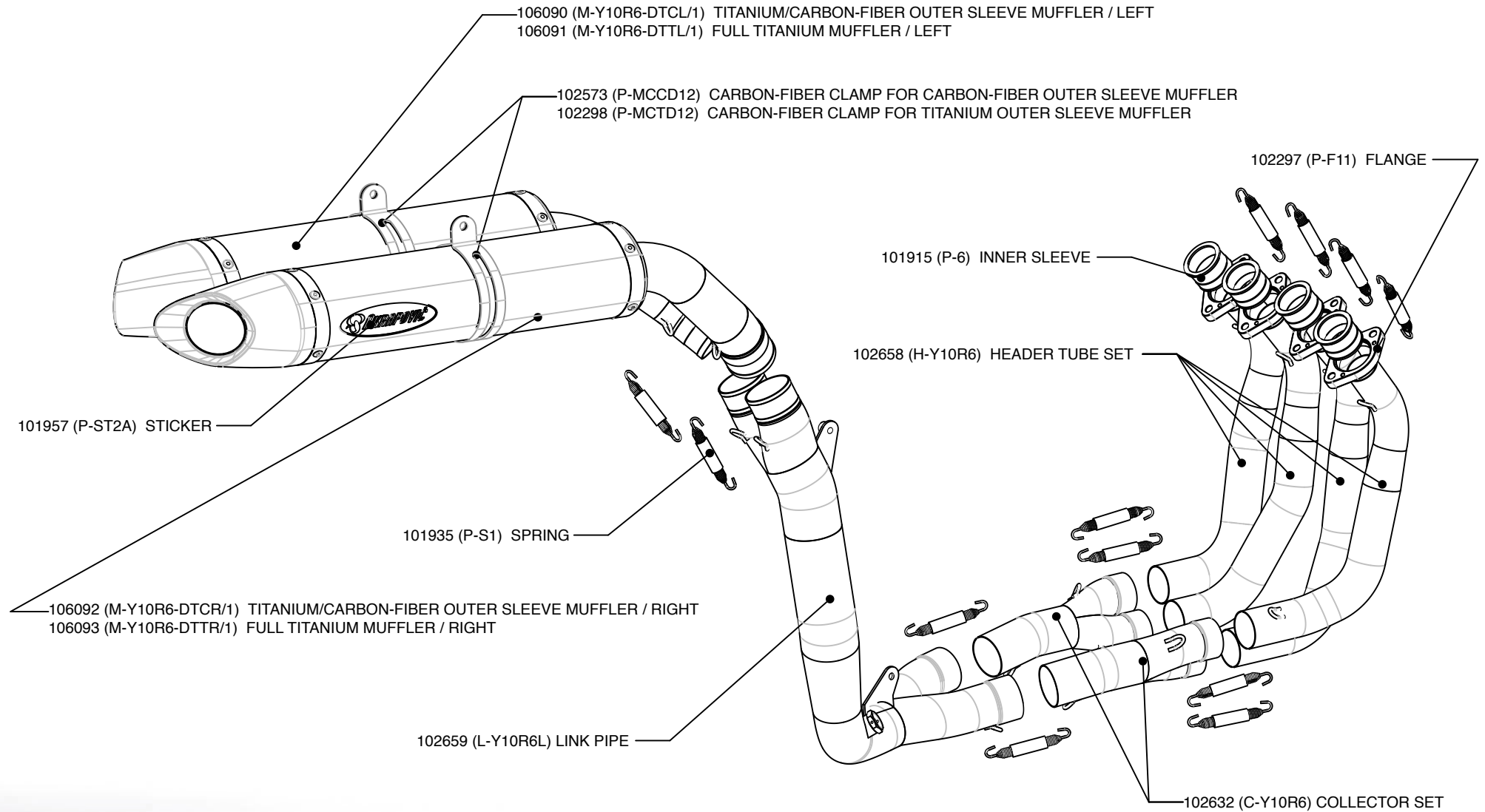

Akrapovic Exhaust System Technology copyright 2006, all rights reserved

Road Program

Product code: 106112 (S-Y10R6L-DTC/1), 106112 (S-Y10R6L-DTC/1) racing

Akrapovic Racing & Evolution Exhaust System

for the Yamaha YZF R1 (2004 - 2006)

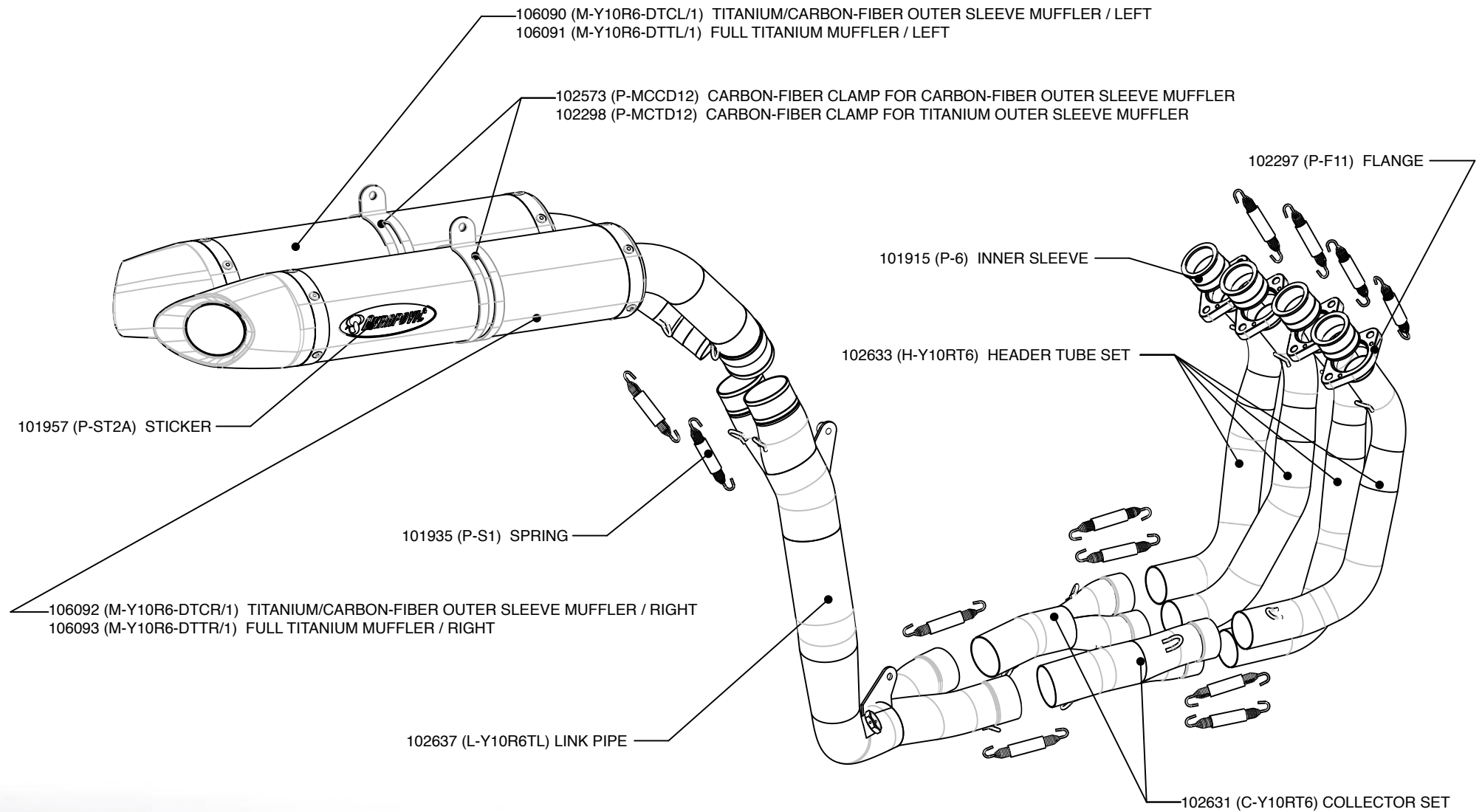

Akrapovic Exhaust System Technology copyright 2006, all rights reserved

Road Program

Product code: 106088 (S-Y10RFT6TL-DTC/1), 106089 (S-Y10RFT6TL-DTT/1) evolution

Akrapovic Racing & Evolution Exhaust System

for the Yamaha YZF R1 (2004 - 2006)

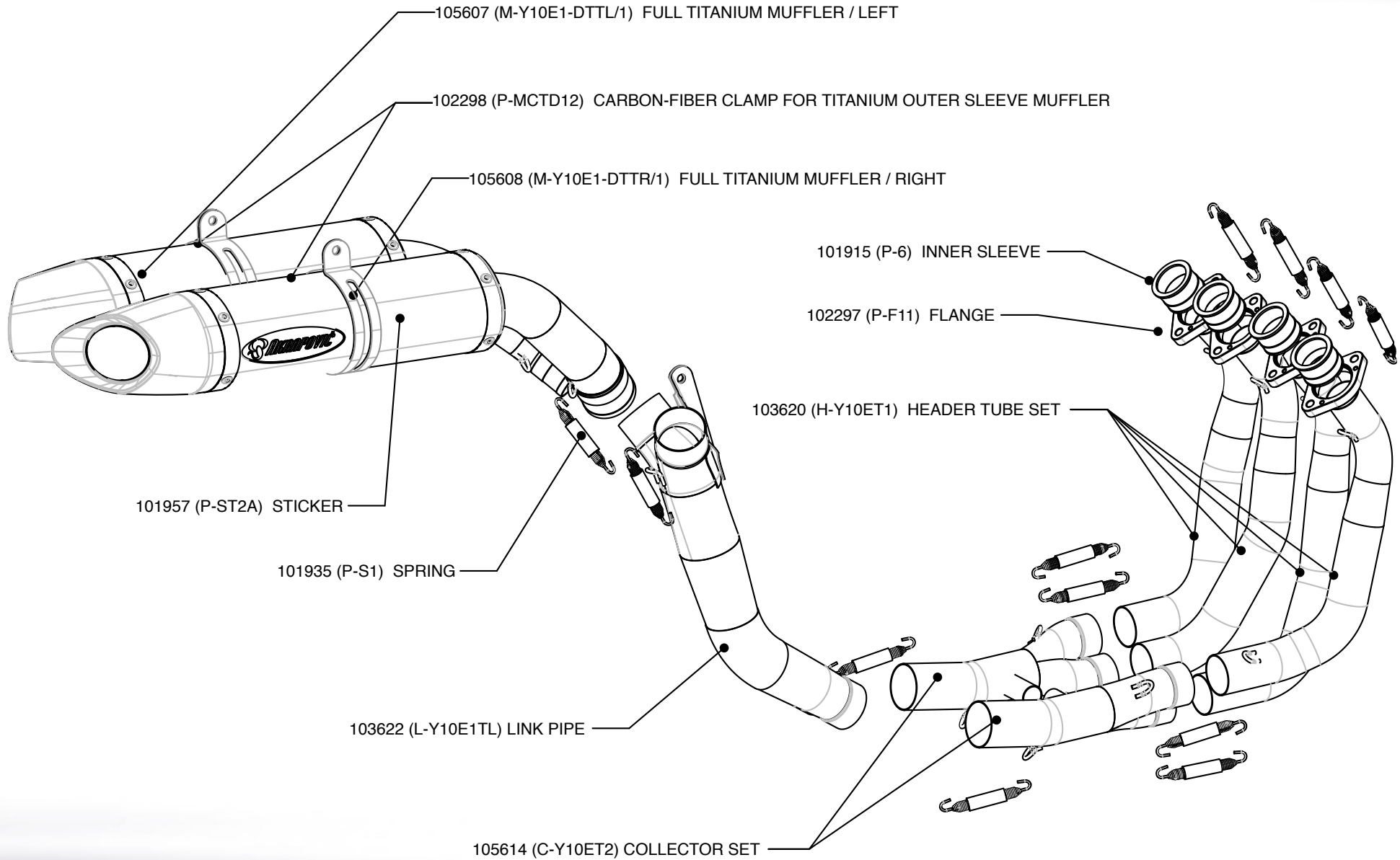

Akrapovic Exhaust System Technology copyright 2006, all rights reserved

Road Program

Product code: 105611 (S-Y10EFT2TL-DTT/1) evolution KIT



Akrapovic Racing & Evolution Exhaust System for the Yamaha YZF R1 (2004 - 2006)

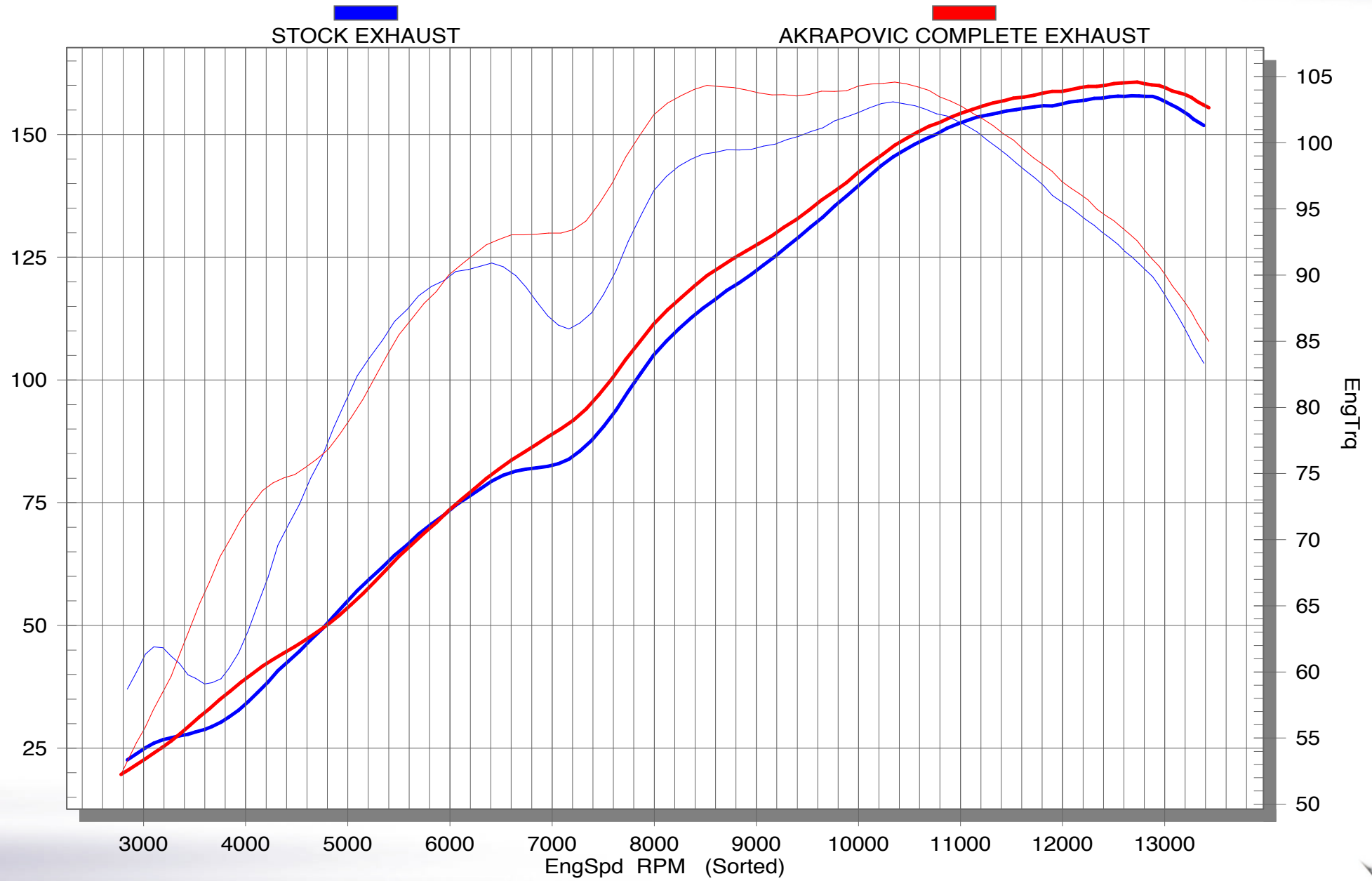

Road Program

Product code: 106112 (S-Y10R6L-DTC/1), 106112 (S-Y10R6L-DTC/1) racing
 106088 (S-Y10RFT6TL-DTC/1), 106089 (S-Y10RFT6TL-DTT/1) evolution
 105611 (S-Y10EFT2TL-DTT/1) evolution KIT



Akrapovic Exhaust System Technology copyright 2006, all rights reserved