



Suzuki GSX-R 1000 (2007)

Racing/Evolution Twin Exhaust System

Akrapovic Racing/Evolution Twin Exhaust System

for the Suzuki GSX-R 1000 (2007)

The Racing and Evolution exhaust systems are the top of the line of the Akrapovic range, designed for riders who demand the most from their exhaust system in terms of both quality and performance. This is the perfect tuning for shaving seconds from your lap times on any track. The Racing and Evolution versions for the Suzuki differ only in their materials. The header tubes for both systems (including the Evolution 2) are partially formed using HYDROFORMING technology! With Akrapovic Racing or Evolution system you will benefit from a major power increase and weight savings compared to the stock Suzuki exhaust system. The systems are for racing purposes only as they are not homologated for street use.

PERFORMANCE

Measurements of the Akrapovic EVOLUTION TWIN system on the SUZUKI GSX-R 1000 (without noise damper):

The system provides a linear increase throughout the entire range, with the greatest increase at the very top of the range. With the Evolution the rear wheel puts out a huge 176.3 HP at 12150 rpm. The max. increased power is an incredible 12.9 HP at 6800 rpm.

The torque curve also reflects the exhaust system upgrade. The engine is more responsive in the low end and will provide much more torque through entire rpm range.

CONFIGURATION

The 4-2-1-2 configurations of the RACING and EVOLUTION OPEN systems are identical, differing only in material selection. The RACING uses stainless steel, the EVOLUTION titanium. The upper part of the header tubes are conical and formed using the state-of-the-art HYDROFORMING procedure, where the tubes are formed using pressurized water. Using this procedure we have obtained maximum exploitation of the exhaust gas flow. The system leads into two cylindrical collectors, and from there into a single conical link pipe and two mufflers. The muffler outer sleeve is available in either carbon-fiber or titanium, while the outlet cap is available only in carbon-fiber. The performance is unchanged in either case. The interior of the muffler is also made of titanium. A carbon-fiber muffler bracket is available as an option. All tubes are connected with sleeve joints held together with silicon-shielded tensioning springs. Mufflers are attached to the motorcycle with carbon-fiber clamps.

	PERFORMANCE		
	stock	AKRAPOVIC	max. increased power
max. rear wheel power HP / rpm (measured on SuperFlow Cycle Dyn)	170.2 / 12100	176.3 / 12150	12.9 / 6800

	CONFIGURATION		
	header tubes	collector	link pipe
material	S.S. / Ti	S.S. / Ti	S.S. / Ti
tube shape	CONICAL	CYLINDRICAL	CONICAL

interference crossover tubes	YES	lambda sensor	YES	
header tube inner sleeves	S.S. CNC MACHINED	header tube flanges	ALU CNC MACHINED	
header tubes - collector connection	SLEEVE JOINT + SILICON SHIELDED SPRING	collector / header tube - link pipe connection	SLEEVE JOINT + SILICON SHIELDED SPRING	
link pipe - muffler connection	SLEEVE JOINT + SILICON SHIELDED SPRING	muffler inlet cap / outlet cap	Ti / Carb.-fiber	
muffler metal interior	Ti	muffler outer sleeve	Ti / Carb.-fiber	
muffler clamp	CARBON-FIBER	muffler bracket	Optional: Carbon-fiber	
muffler insert	EU	YES(track legal)	heat shield	-
	US	-	catalytic converter	-

	ADDITIONAL DATA				
	stock	AKRAPOVIC		difference	
		RACING	EVOLUTION	stock - RACING	stock - EVOLUTION
weight comparison (kg)	7.18	4.89	4.18	2.29	3.00
noise measurements (dB / rpm)	stock		AKRAPOVIC		
	98.6 / 5500		99 / 5500 (Evolution 1)		
possibility of periodic service without removing A.E.S.	oil		oil filter		
	YES		YES		
legal for street use	NO				

Technical specifications of Akrapovic exhaust systems and related products subject to change without notice.

Product code: 1077756 (S-S10R6-ZC), 107757 (S-S10R6-ZT)
107705 (S-S10RFT6T-ZC), 107706 (S-S10RFT-6T-ZT)

Akrapovic Racing/Evolution Twin Exhaust System for the Suzuki GSX-R 1000 (2007)



Akrapovic Exhaust System Technology copyright 2007, all rights reserved

Road
Program

Product code: 107756 (S-S10R6-ZC), 107757 (S-S10R6-ZT)
107705 (S-S10RFT6T-ZC), 107706 (S-S10RFT-6T-ZT)

Akrapovic Racing/Evolution Twin Exhaust System for the Suzuki GSX-R 1000 (2007)



Akrapovic Exhaust System Technology copyright 2007, all rights reserved

Road
Program

Product code: 107756 (S-S10R6-ZC), 107757 (S-S10R6-ZT)
107705 (S-S10RFT6T-ZC), 107706 (S-S10RFT-6T-ZT)

Akrapovic Racing/Evolution Twin Exhaust System for the Suzuki GSX-R 1000 (2007)



Akrapovic Exhaust System Technology copyright 2007, all rights reserved

Road Program

Product code: 107756 (S-S10R6-ZC), 107757 (S-S10R6-ZT)
107705 (S-S10RFT6T-ZC), 107706 (S-S10RFT-6T-ZT)

Akrapovic Racing Twin Exhaust System

for the Suzuki GSX-R 1000 (2007)

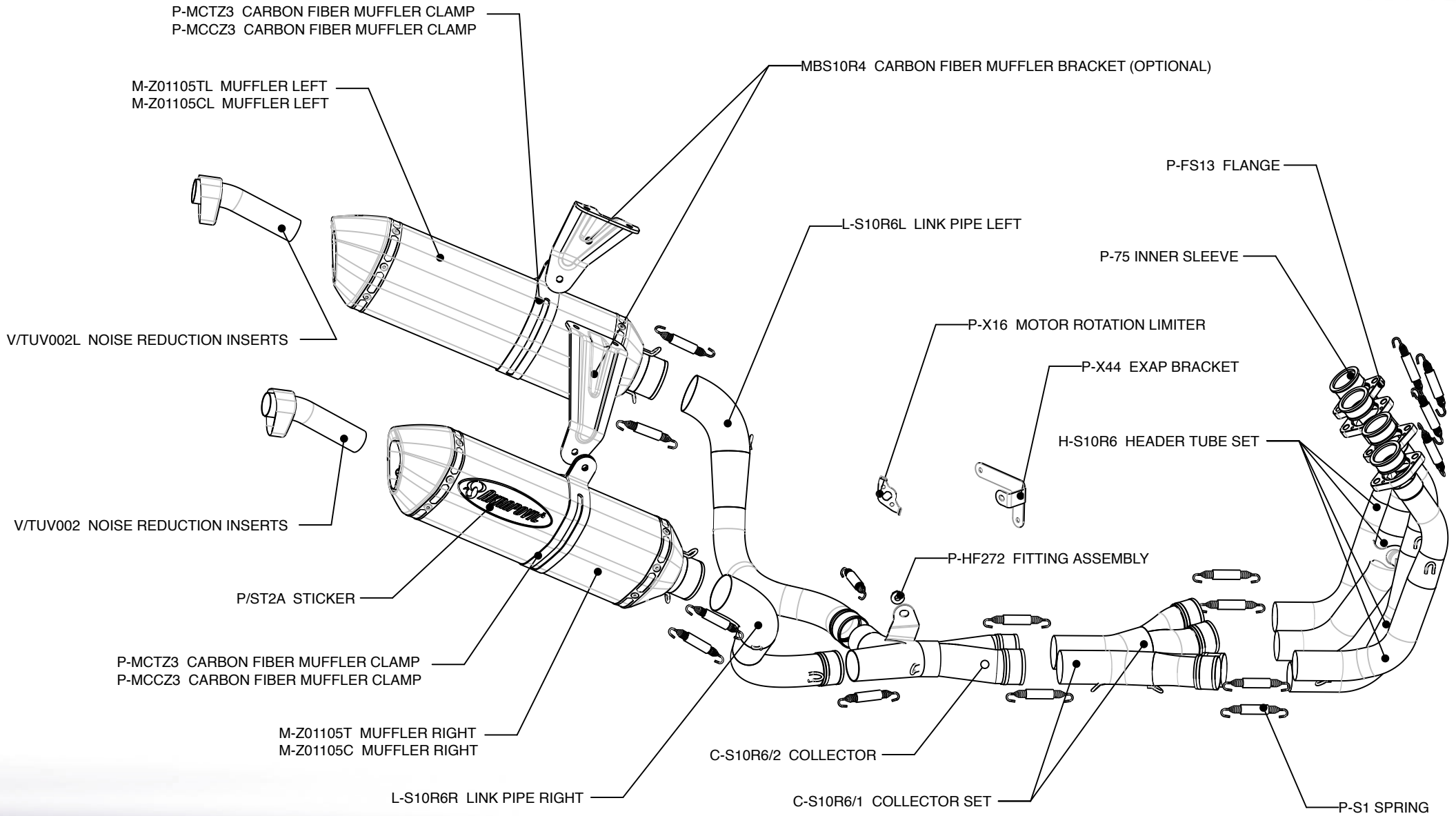

Akrapovic Exhaust System Technology copyright 2007, all rights reserved

Road Program

Product code: 107756 (S-S10R6-ZC), 107757 (S-S10R6-ZT)

Akrapovic Evolution Twin Exhaust System for the Suzuki GSX-R 1000 (2007)

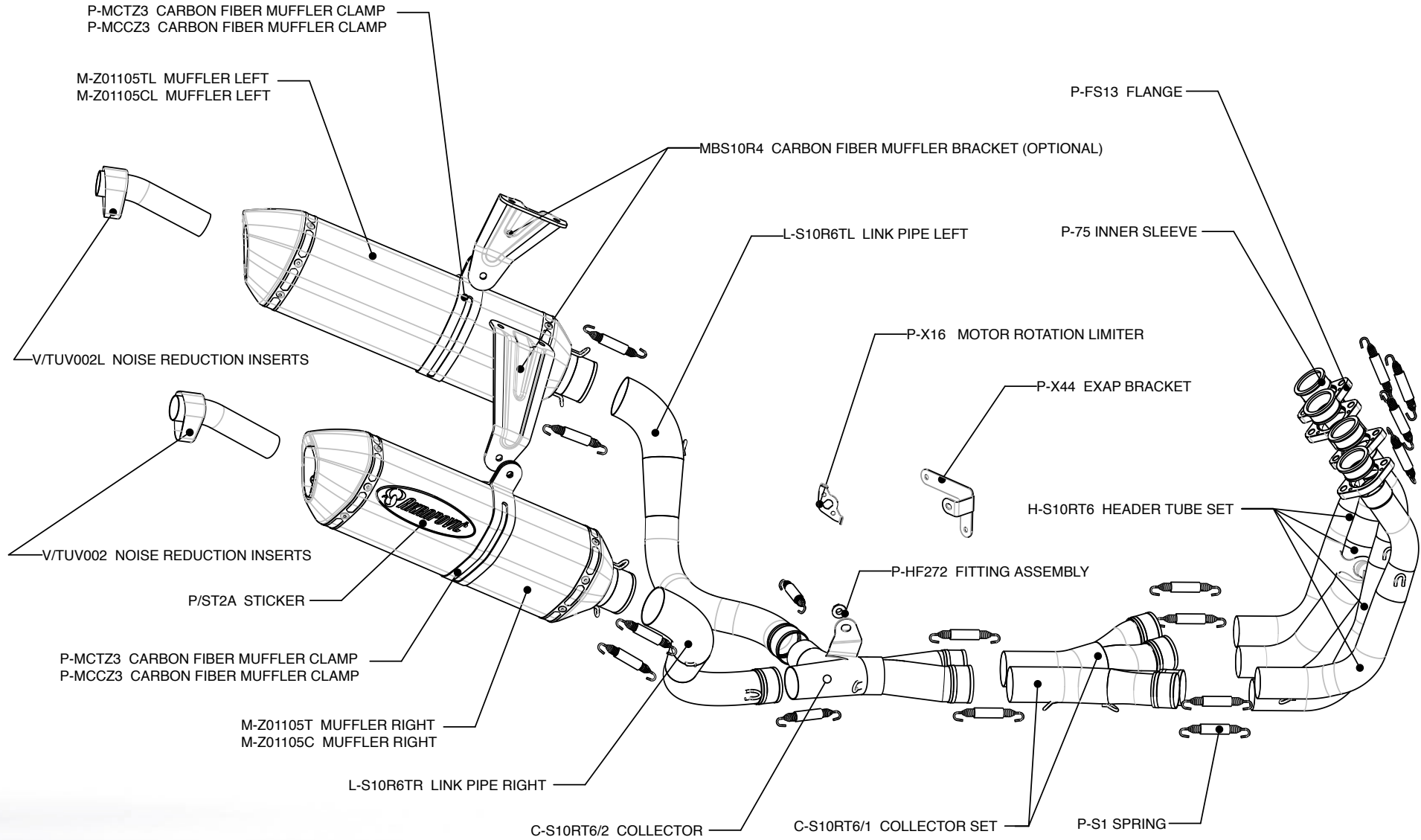

Akrapovic Exhaust System Technology copyright 2007, all rights reserved

Road Program

Product code: 107705 (S-S10RFT6T-ZC), 107706 (S-S10RFT-6T-ZT)



Akrapovic Racing/Evolution Twin Exhaust System for the Suzuki GSX-R 1000 (2007)

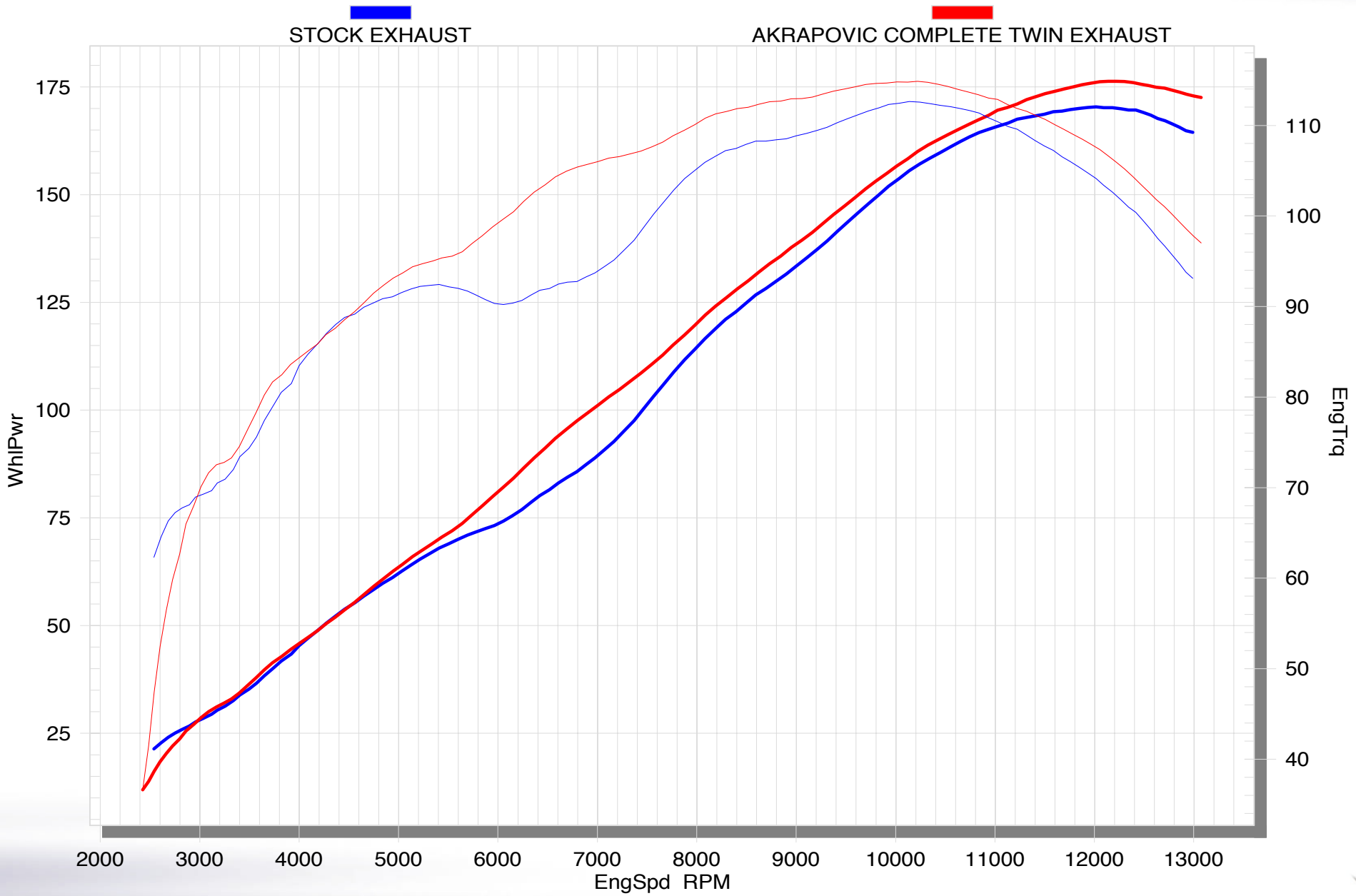

Road Program

Product code: 107756 (S-S10R6-ZC), 107757 (S-S10R6-ZT)
107705 (S-S10RFT6T-ZC), 107706 (S-S10RFT-6T-ZT)



Akrapovic Exhaust System Technology copyright 2007, all rights reserved