



Kawasaki ZX-6 R (2007)

Slip-On & Slip-On Street Legal Exhaust System

Akrapovic Slip-On & Slip-On Street Legal Exhaust System for the Kawasaki ZX-6 R (2007)

The ZX 6-R, Kawasaki's speedster in the 600 class, is definitely a head-turner. To improve its sleek looks even further we have developed an Akrapovic SLIP-ON system which fits smoothly into the lines of the Kawasaki. The Akrapovic SLIP-ON exhaust system is designed for riders who are looking for an excellent combination of aesthetics, quality and price. System is available in street legal and sportier open version.

PERFORMANCE

Measurements of the Akrapovic SLIP-ON system on the KAWASAKI ZX 6-R (without noise damper):

Power & Torque: Akrapovic power curve follows the stock curve up to 6000 rpm, and then shows an noticeable increase which extends right into the overrev range. The ZX 6-R receives 117,8 HP at 14325 rpm, which is 3 HP more than with stock exhaust system. The torque curve is increased throughout the entire rpm range and gives more easy to drive engine characteristics.

CONFIGURATION

The Akrapovic SLIP-ON system is made of stainless steel (link pipe), titanium (complete muffler), and the carbon-fiber outlet cap cover. All that gives the system a stylish racing look. A cylindrical stainless steel link pipe is connected to the muffler with a sleeve joint, secured with silicon-shielded tensioning springs. At the other end the link pipe is attached to the stock header tube with a stock metal clamp. It is attached to the frame with a special Akrapovic carbon-fiber clamp.

	PERFORMANCE		
	stock	AKRAPOVIC	max. increased power
max. rear wheel power HP / rpm <small>(measured on Dynojet ATV)</small>	114.9 / 14200	117.8 / 14325	3 / 14325

	CONFIGURATION		
	header tubes	collector	link pipe
material	-	-	STAINLESS STEEL
tube shape	-	-	CYLINDRICAL

interference crossover tubes	-	lambda sensor	NO	
header tube inner sleeves	-	header tube flanges	-	
header tubes - collector connection	-	collector / header tube - link pipe connection	STOCK METAL CLAMP +STOCK GRAPHIT GASKET	
link pipe - muffler connection	SLEEVE JOINT + SILICON SHIELDED SPRINGS	muffler inlet cap / outlet cap	TITANIUM / CARBON-FIBER	
muffler metal interior	TITANIUM	muffler outer sleeve	TITANIUM	
muffler clamp	CARBON-FIBER	muffler bracket	MUFFLER HEAT SHIELD BRACKETS: STAINLESS STEEL LICENCE PLATE HOLDER BRACKET: STAINLESS STEEL	
muffler insert	EU	NOISE DAMPER	heat shield	NO (STOCK)
	US	-	catalytic converter	NO (STOCK)

	ADDITIONAL DATA				
	stock	AKRAPOVIC		difference	
		S.S. link pipe	TITANIUM link pipe	stock - S.S.	stock - titanium
weight comparison (kg)	/	/	-	/	-
noise measurements (dB / rpm)	stock		AKRAPOVIC		
	95 / 7000		101.9 / 7000 (homologated)		
possibility of periodic service without removing A.E.S.	oil		oil filter		
	YES		YES		
legal for street use	NO / YES (homologated)				

Technical specifications of Akrapovic exhaust systems and related products subject to change without notice.

Akrapovic Exhaust System Technology copyright 2007, all rights reserved

Road Program

Product code: S-K6SO5-ACT
S-K6SO5-HACT Homologated



Akrapovic Slip-On & Slip-On Street Legal Exhaust System for the Kawasaki ZX-6 R (2007)



Akrapovic Exhaust System Technology copyright 2007, all rights reserved

Road
Program

Product code: S-K6SO5-ACT
S-K6SO5-HACT Homologated

Akrapovic Slip-On & Slip-On Street Legal Exhaust System for the Kawasaki ZX-6 R (2007)



Akrapovic Exhaust System Technology copyright 2007, all rights reserved

Road Program

Product code: S-K6SO5-ACT
S-K6SO5-HACT Homologated

Akrapovic Slip-On & Slip-On Street Legal Exhaust System for the Kawasaki ZX-6 R (2007)



Akrapovic Exhaust System Technology copyright 2007, all rights reserved

Road
Program

Product code: S-K6SO5-ACT
S-K6SO5-HACT Homologated

Akrapovic Slip-On Legal Exhaust System for the Kawasaki ZX-6 R (2007)

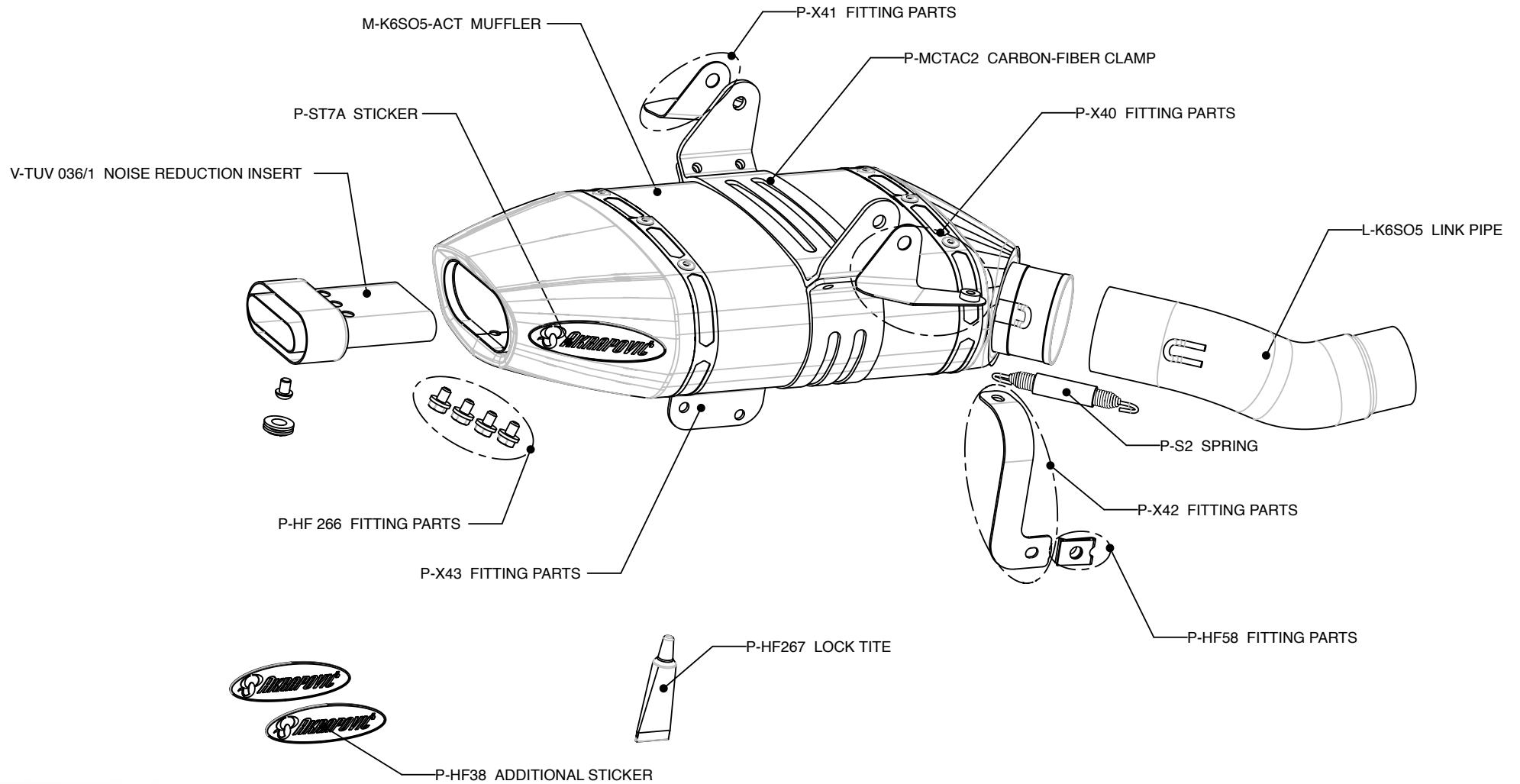

Akrapovic Exhaust System Technology copyright 2007, all rights reserved

Road Program

Product code: S-K6SO5-ACT



Akrapovic Slip-On Street Legal Exhaust System for the Kawasaki ZX-6 R (2007)

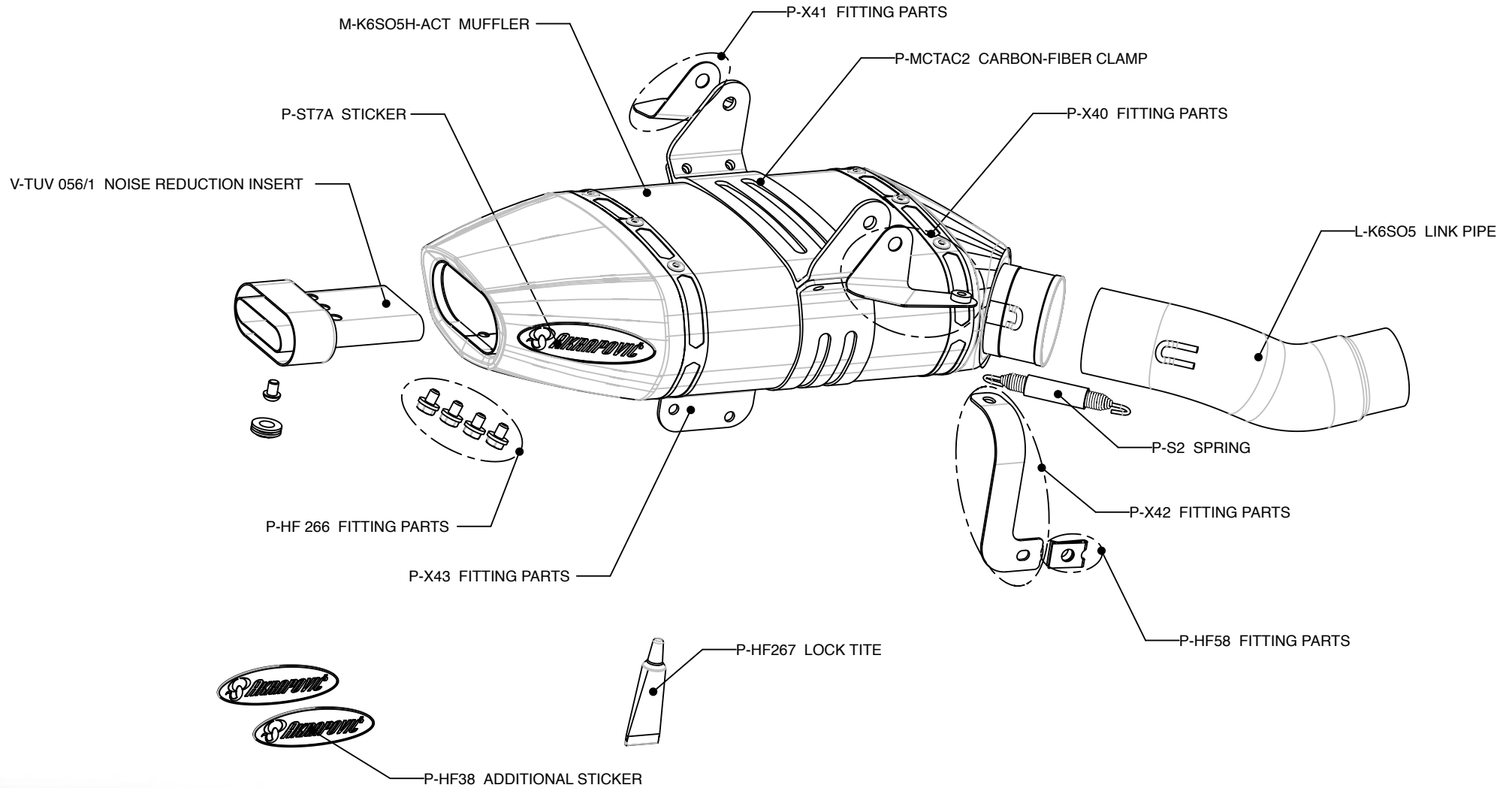

Akrapovic Exhaust System Technology copyright 2007, all rights reserved

Road Program

Product code: S-K6SO5-HACT Homologated



Akrapovic Slip-On & Slip-On Street Legal Exhaust System for the Kawasaki ZX-6 R (2007)

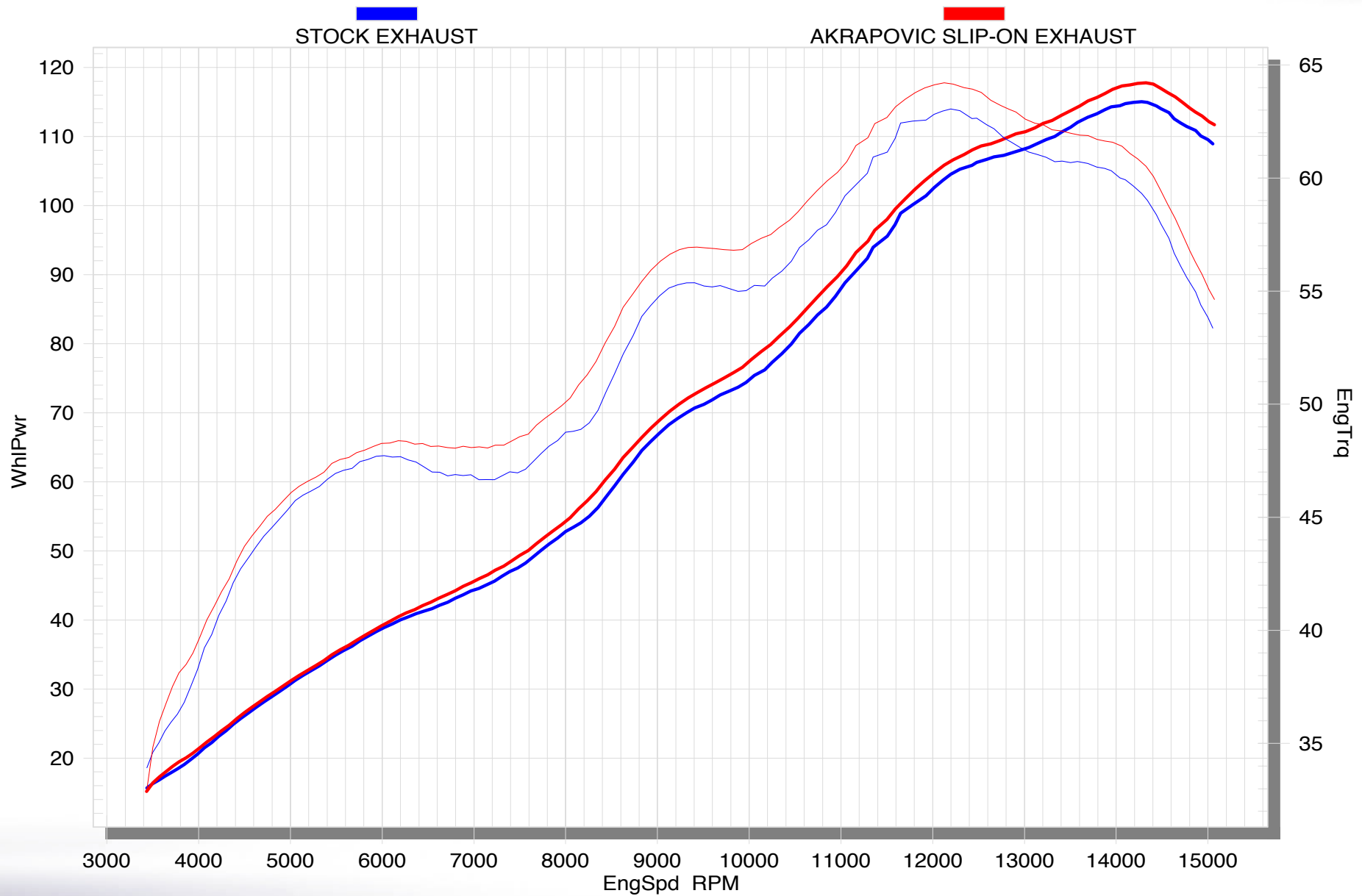

Akrapovic Exhaust System Technology copyright 2007, all rights reserved

Road Program

Product code: S-K6SO5-ACT
S-K6SO5-HACT Homologated

